



Aluminum, Steel and Poly Crossover, Innerside and Chest Truck Boxes Trailer Tongue Storage Boxes

IMPORTANT INFORMATION

Please Read And Save This Form

In the event you need to obtain Replacement Parts, we will need the Model Number of your Delta product. Please locate the Model Number of your product and list it in the space below.

Model No. _____ Date Purchased _____

Keys

Your Delta product is shipped with two keys. We have hundreds of different locks and key patterns to fit the locks. The Key Code for the key to fit the lock(s) for your Delta product is stamped on the key and on the cover of the key entry slot of the lock.

You will need this Key Code to obtain additional or replacement keys. Write the Key Code in the space below for future reference.

Key Code _____

Gas Spring Lid Lifts

Many of our products have one or two Gas Spring Lid lifts to assist with opening and closing the lid.

To obtain a replacement Gas Spring Lid Lifts used on your product, we will need the Model Number that appears on a label on the barrel of the Gas Spring. Please locate the code on the Gas Spring and write it in the space below for future reference.

Gas Spring Lid Lift Model No. _____

To Obtain Keys, Gas Spring Lid Lifts And Other Replacement Parts

Contact our Customer Service Department at 800-643-0084 and Press 1 between the hours of 8:30 AM and 4:30 PM Central Time Monday – Friday. Or, by email at parts@danahertool.com.

To help us serve you, please have the above information available. We will need a street address to send you the item(s) you request.

Orders for Keys, Gas Spring Lid Lifts and other Replacement Parts are normally shipped within two business days.

Prices for Parts do not include shipping charges and are subject to applicable taxes.

You can send a money order or personal check for parts orders. COD shipments not available.

We also accept MasterCard and Visa information only by phone. Do not send Credit Card information by email for your protection.

ADJUSTABLE STRIKER INSTRUCTIONS

Some Delta Aluminum Crossovers are equipped with Adjustable Strikers. The adjustable striker assembly may be adjusted horizontally or vertically by loosening the lock nuts and repositioning the striker bracket (B) or striker pin (C) as required. For best results, loosen only one lock nut at a time.

• The horizontal adjustment (if necessary) should be made first.

- Loosen the lock nut (A) at the top of the striker assembly.
- Move the striker bracket (B) so the striker pin (C) passes just to the left of the guide plate (D) as the lid is closed. The striker pin (C) should not make contact with the guide plate (D).
- Positioning the striker pin (C) too far to the left will prevent the latch hook (E) from closing fully.
- Re-tighten the lock nut (A).

• For vertical adjustment:

- Loosen the striker pin lock nut (F) on the back side of the striker bracket (B).
- Move the striker pin (C) up or down to achieve the desired lid tightness. Striker pin (C) should be positioned to allow the lid to close just tight enough to seal against the weather stripping. Moving Striker Pin (C) too far down will make the lid difficult to close.
- Re-tighten the lock nut (F).

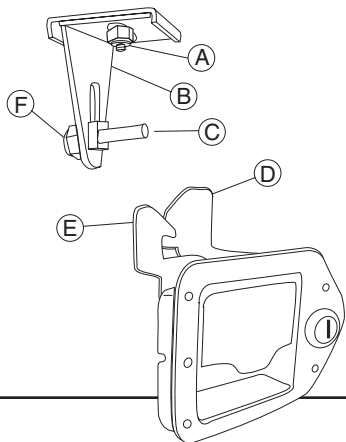

(see back for more information)

Crossover Installation Instructions

A Crossover can be installed by drilling holes in tops of side walls for bolts or using J-Bolts which do not require holes in side walls.

To obtain a set of J-Bolts, call our Customer Service at 800-643-0084 between 8:30 AM and 4:30 PM Central Time.

Place the Crossover in the desired location with the lid fully open to insure proper clearance between the lid, back wall and cab. Be sure the fully open lid will not hit the rear window. Mark the locations of the two slots on each end on the top of the bed side walls. Remove the Crossover.

If you are using J-Bolts, follow Steps A – F. If you are bolting it on the side walls, follow Steps G – I.

- A. Determine if J-Bolts can be hooked under side wall tops and line up with the locations marked. See Figure 1. If so, proceed to Step C.
- B. If J-Bolts can not be aligned with the locations marked, determine where J-Bolts can be located on the side walls. Carefully measure locations. Drill 5/16" holes in Crossover to match locations of J-Bolts.
- C. Insert J-Bolt threaded ends up through the holes from the bottom. (See Figure 1). Place nylon retaining washer on J-Bolts to hold them in place. Put the Crossover in the desired location. Hook the curved ends of J-Bolts under tops of side walls.
- F. Use a flat washer and lock nut on J-Bolts to hold Crossover in place.
- G. Determine if 3/8" dia. holes drilled in locations marked will damage wiring under tops of side walls. If not, drill holes and proceed to Step I.
- H. If holes cannot be drilled in the locations marked, determine where holes can be drilled and measure these carefully. Drill holes in ends of the Crossover to match the new locations.
- I. Place mounting pads under Crossover where it sits on side walls.
- J. Position Crossover so holes match. Put 5/16"x 1" hex head bolts with flat washers in holes from top and tighten with nuts on bottom.

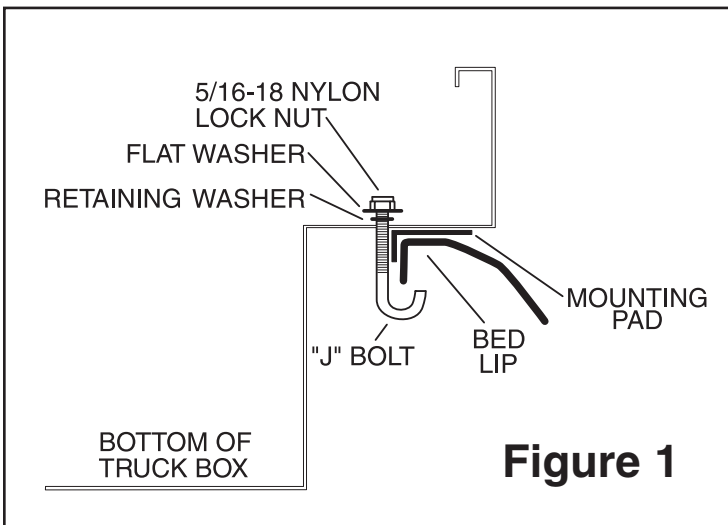

Innerside Box Installation Instructions

- A. Determine location of box on truck rail. Drill 9/32" diameter holes through box and truck rail at front and rear. Fasten at front and rear using 1/4" flat washer, 1/4" lock nut and 1/4" x 1" bolt. Install the flat washers inside the box.
NOTE: Position box so that the screw holes drilled in the truck bed in Step C will not interfere with truck frame members, electrical wiring, hydraulic lines, etc. (See Diagram A). Be sure the box is level before drilling any further holes.
- B. Position the mounting leg against box at each end. Make certain that you allow at least 48" between the mounting legs on each side to permit stacking of construction material between the wheel wells. (See Diagram A). Drill 9/32" diameter holes through the box and fasten the legs to the box using 1/4" x 1/2" bolt, 1/4" flat washer and 1/4" lock nut.
- C. Drill 9/32" diameter holes through the bottom of the truck bed and fasten the legs to the truck bed using 1/4" flat washer, 1/4" lock nut and 1/4" x 1" bolt. Install the flat washer on the top side of the mounting leg, bottom flanges and the nuts on the underside of the truck bed.

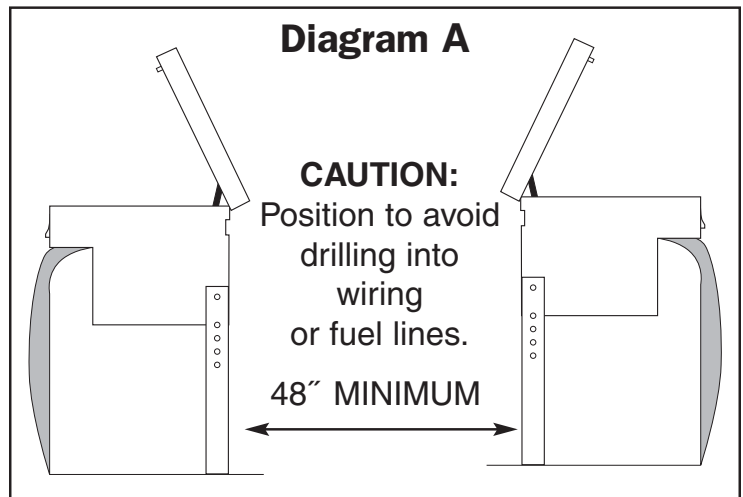

Chest Installation Instructions

- A. Position tool box against front of the truck bed.
- B. Note location of mounting holes and check beneath bed for any possible interference.
- C. Drill through the mounting holes with a 3/16" drill.
- D. Secure tool box to truck bed with sheet metal screws.
- E. Plug holes in bottom of box with 1" plugs provided.

Trailer Tongue Box Installation Instructions

When bolting a Trailer Tongue Box to a trailer, drill the holes for bolts in the aluminum reinforcing bar in the front and rear bottom of the box.

Delta One-Year Limited Warranty

This warranty is made by Delta Consolidated Industries, Inc. (DCI) to the original purchaser of this product made by DCI and is valid for one (1) year from date of purchase upon presentation of a copy of the original sales receipt at the time of the warranty claim. DCI warrants that the products it makes are free from defects in materials and workmanship at the time of the sale. This warranty does not cover damage caused by accident or unreasonable or unintended use of the product. Modification, disassembly and / or re-assembly of the product will invalidate this warranty. Damage to the contents of the box, vehicle or other consequential damages are excluded from this warranty.

In the case of a nonconforming product, you should return the product to the point of purchase or an authorized Delta retail / dealer store. The retailer or dealer will either repair or replace the product at their option if the product should prove to be defective in material or workmanship. If you feel that you have not been offered a satisfactory resolution to your Warranty issue, you may submit your request in writing for further consideration to the Warranty Department, Delta Consolidated Industries, Inc., P O Box 1846, Jonesboro, AR 72403-1846. Explain in writing the nature of the problem and why you feel you have not been offered a satisfactory solution. Be sure to include the Model Number of the product and a copy of the sales receipt.

Note: This warranty applies solely to domestic sales and shipments made within the continental USA. It gives you specific legal rights in the USA, and you may have other rights imposed by one or more states in the USA.